

# USING A HELIUM BUBBLE GENERATOR TO VISUALIZE AIRFLOW PATTERNS IN AND AROUND BUILDING MODELS

Rashed Al-Shaali  
PhD Student, UCLA,  
Los Angeles, CA 90095  
alshaali@ucla.edu  
Instructor at UAEU School Architecture

Pierre Koenig  
USC School of Architecture  
Los Angeles, CA 90089

Marc Schiler  
USC School of Architecture  
Los Angeles, CA 90089

## ABSTRACT

This paper presents a technique in observing wind patterns and velocities inside and around buildings models in a very simple and inexpensive wind tunnel. This would allow architects to predict the airflow patterns in order to design buildings with better energy performance.

The SAI™ Helium Bubble Generator was used to investigate the air speed and pattern inside clear plastic models. The device produces tiny neutrally buoyant bubbles filled with helium that follow complex laminar and turbulent airflow pattern throughout the entire flowfield when driven by a fan.

In a dark lab, a slide projector is used to aim a narrow beam of light inside the model. The helium filled bubbles, driven by a fan, glow revealing the airflow patterns. These patterns are recorded using a digital camcorder at 30 frames per second. In every picture (frame) lines and curves represent traces of bubbles shining under the projector light beam. The beam is controlled by using different slides with various openings shaped as intended.

The velocity at any point in the model is determined by measuring the length of each line or curve using a grid placed at the back side of the model or applied digitally on the picture. Every 1 inch in the picture represents 30 inches per second or 0.76 meters per second.

All the simulated airflow tests were performed on a 1:48 scale model of a building 14' wide, 28' long and 10' high. A wind catcher with three different sizes was attached to the top of the model. All three sizes had the same height but varying throat areas, which represented 33%, 50%, and 100% of the windward façade. The leeward façade contained an exhaust in two general configurations: the first

configuration used the entire façade as an outlet (10' X 14'), while the second used an opening of 4' X 14' placed at varying locations.

## 1. INTRODUCTION

Just like light, wind cannot be seen, yet, the effect is noticed over targeted objects, light gets reflected by objects which makes them visible, wind moves movable objects providing some information about direction and magnitude.

The Helium Bubble Generator is a device that produces neutrally buoyant bubbles filled with helium. The bubbles follow the air flow streamlines and rarely collide with objects. Additionally, the bubbles will follow laminar and turbulent airflows. The Helium Bubble Generator method uses both wind and light to visually show airflow patterns in and around building models. In addition, the speed at any location can be measured using a video camera and video producing software.

## 2. EXPERIMENT GENERAL SETUP

The experiment was preformed in a closed dark room (Fig. 1). The fan, bubble output tube, model and light projector were aligned on one axis.

## 3. CONTROLLING THE LIGHT BEAM

Using a plastic slide with aluminum foil sheet instead of the usual transparent image helped directing the light beam. A small square opening in the aluminum sheet allowed the light beam to go through the model without having any light spills outside the designated areas (Fig. 2).

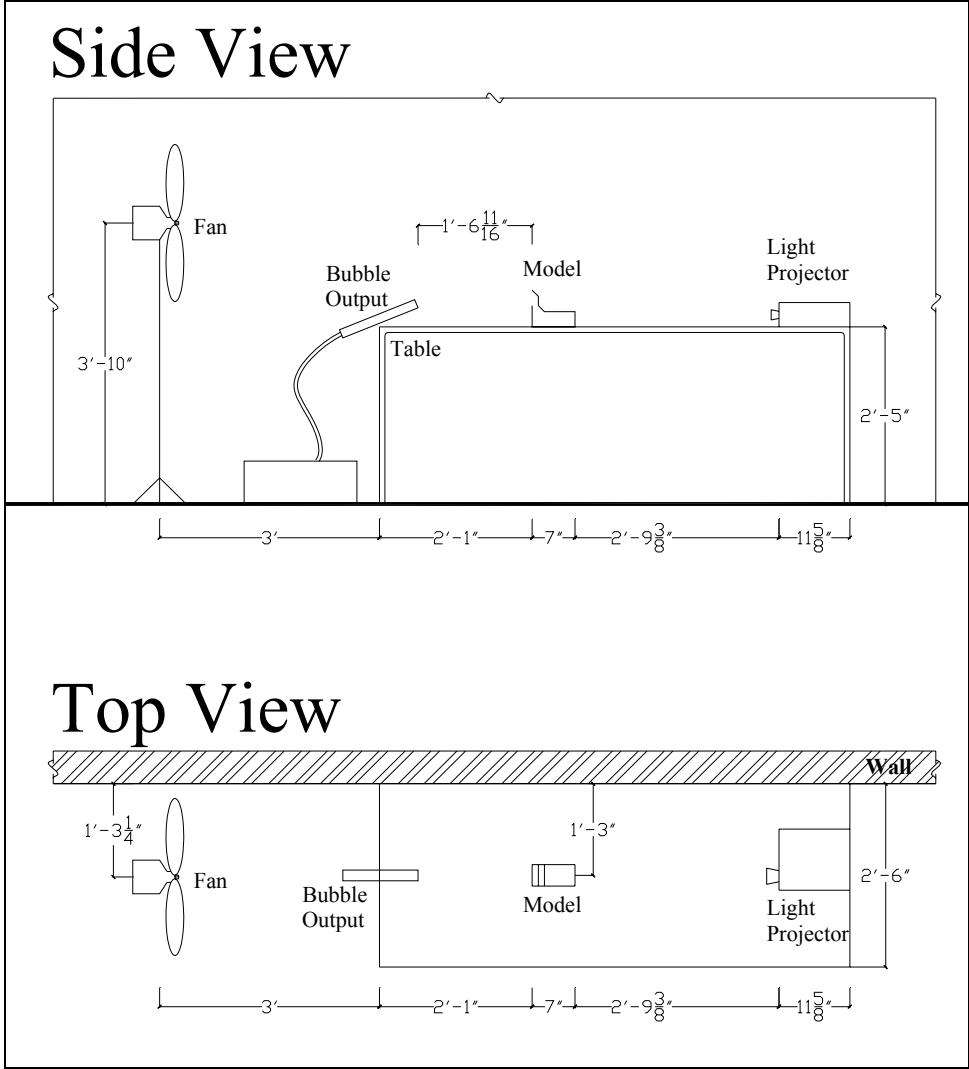

Fig. 1: Experiment General Setup.

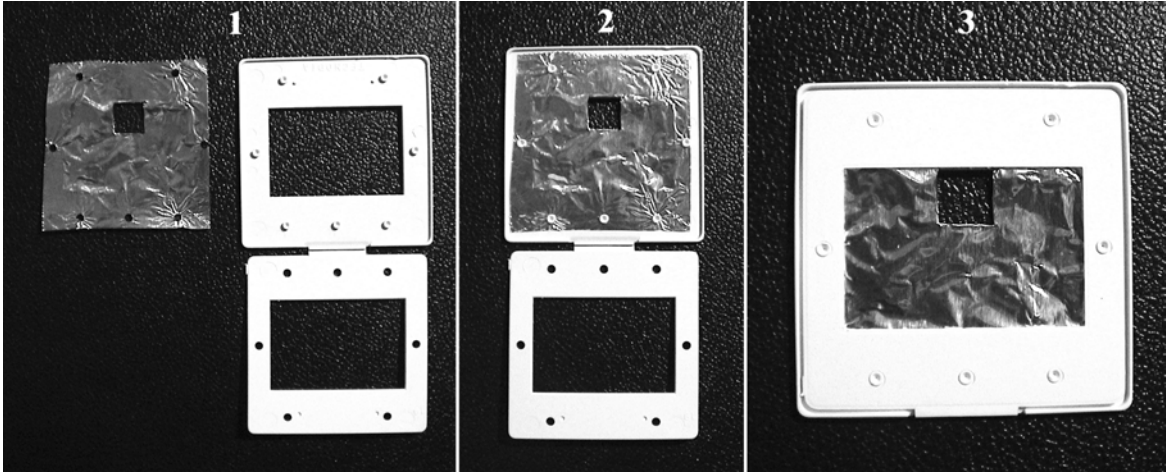

Fig. 2: Plastic slide with aluminum foil sheet to direct the light beam.

#### 4. MEASURING THE VELOCITY

The fan speeds A, B and C are measured by a grid paper that is placed in place of the model in Figure (1). The tests were recorded using a digital camcorder with a 30 frame per second rate. The duration of each frame is 0.033 second. In short, every inch the bubble draws in the picture represents 30 inch per second or 0.76 meters per seconds (Fig. 3).

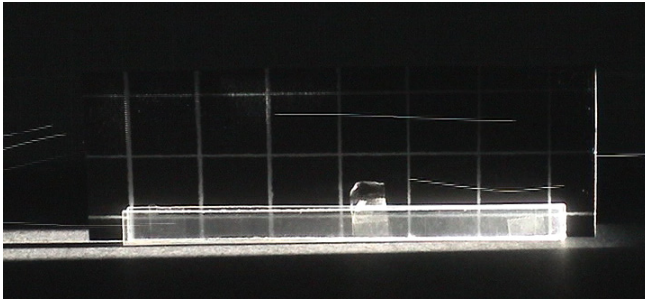

Fig. 3: An example of lines that bubbles represent on one frame.

Fan Speed A = 5 ft/s = 1.5 m/s = 3.4 mph  
 Fan Speed B = 7.5 ft/s = 2.3 m/s = 5.1 mph  
 Fan Speed C = 10 ft/s = 3.1 m/s = 6.8 mph

#### 5. DRAWINGS

All the simulated airflow tests were performed on a 1:48 scale model of a building 14' wide, 28' long and 10' high (Fig. 4)

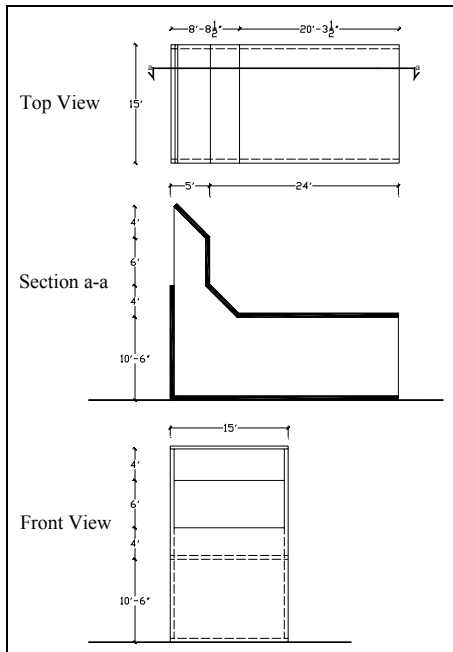

Fig. 4 : Wind Catcher, Top View, Section and Front View.

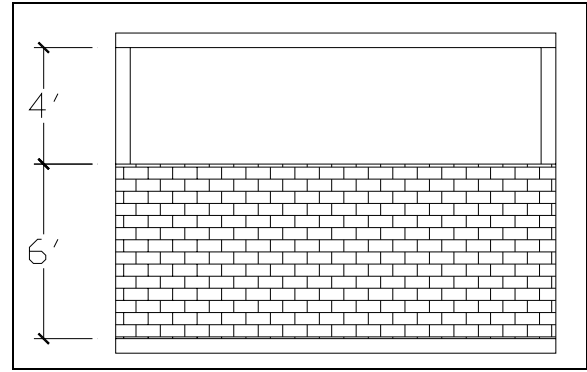

Fig. 5: Leeward Elevation (Exhaust).

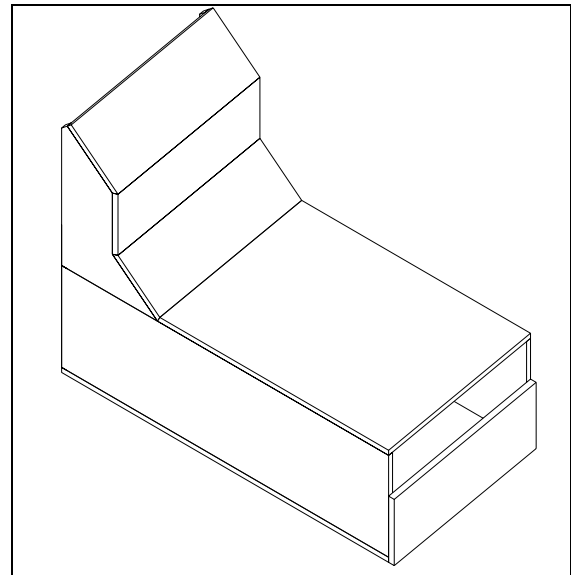

Fig. 6: Axonometric Back View

#### 6. TEST RESULTS

The general flow of the wind takes a curved path to the exit. However, there is some variation appearing at the top of the model where a region of positive pressure is forcing the wind into a loop or vortex.

As for the speed of wind inside the model, the highest speed would be under the wind catcher which is in the first third. Nevertheless, the wind decelerates and reaccelerates throughout the model until it reaches the exhaust, where a speed higher than the one in the middle zone is noticed most of the time

This case I would say shows that the pattern near the exit will not be affected by the size of the wind catcher, however the speed slightly increased (Fig. 7 – 15).

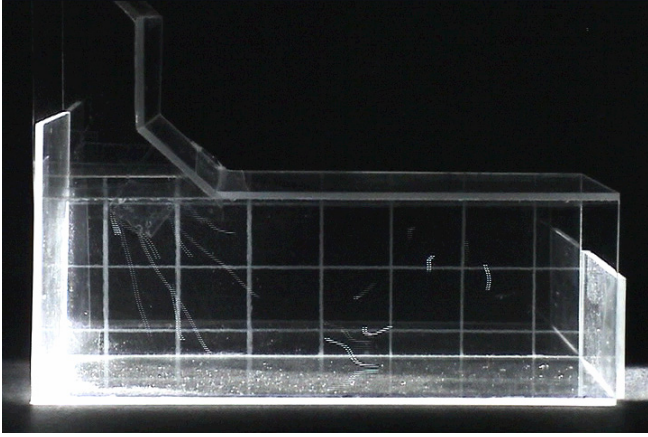

Fig. 7: The Bubbles Entering the Model.

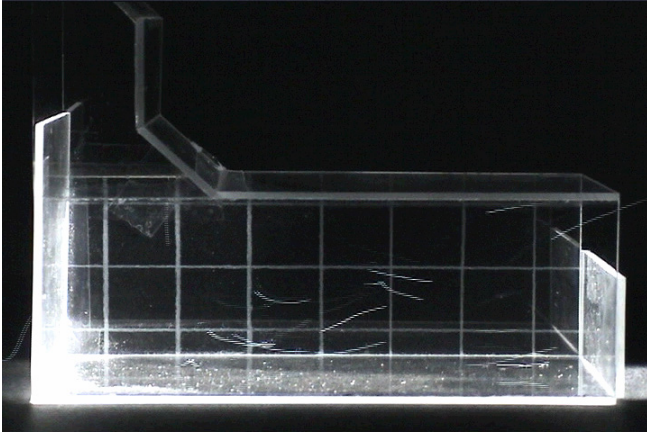

Fig. 10: Bubble Speed 0.57 m/s.

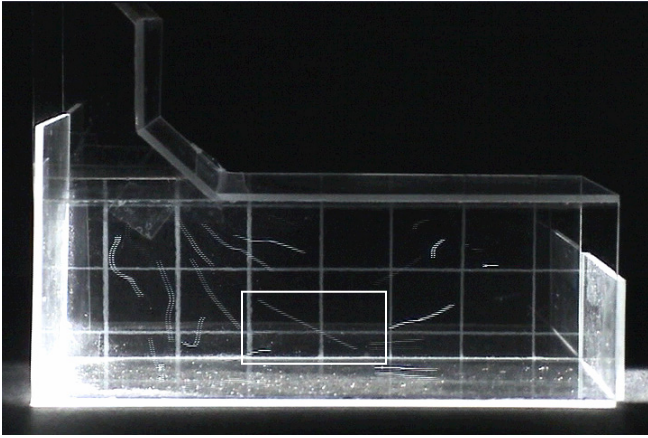

Fig. 8: Bubble Speed 1.33 m/s.

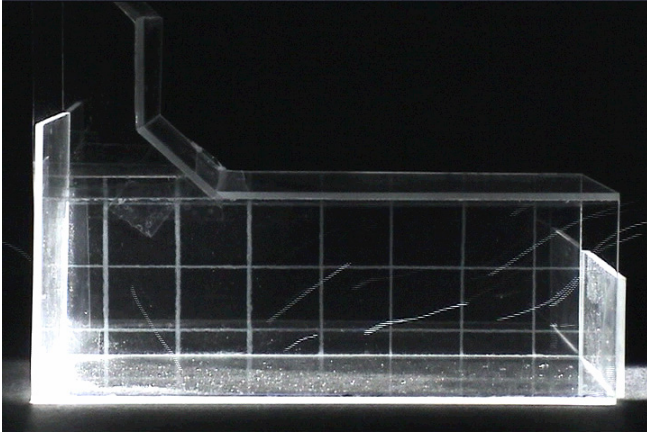

Fig. 11: Bubbles Exiting the Model.

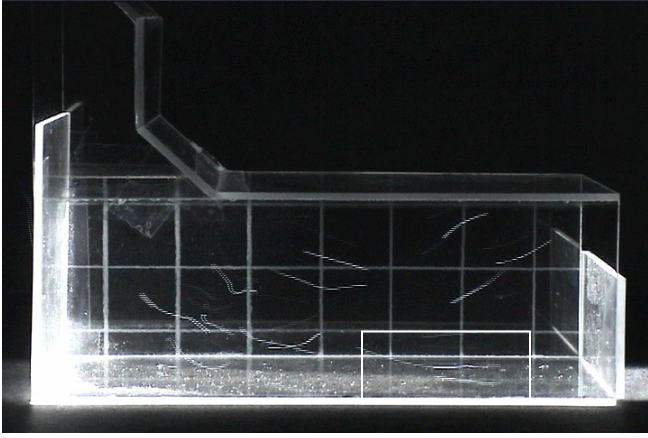

Fig. 9: Bubble Speed 1.71 m/s.

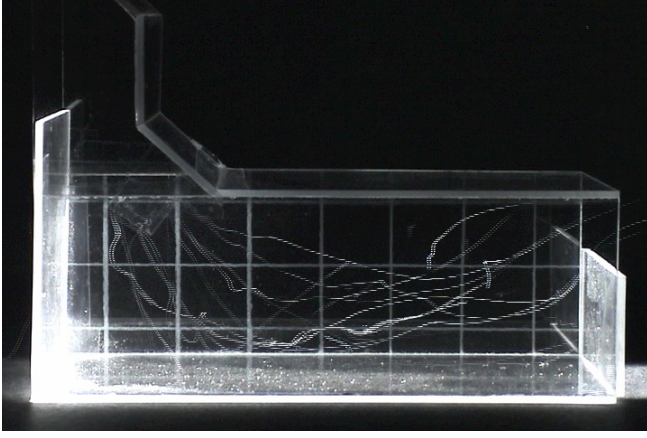

Fig. 12: Seven Frames Combined.

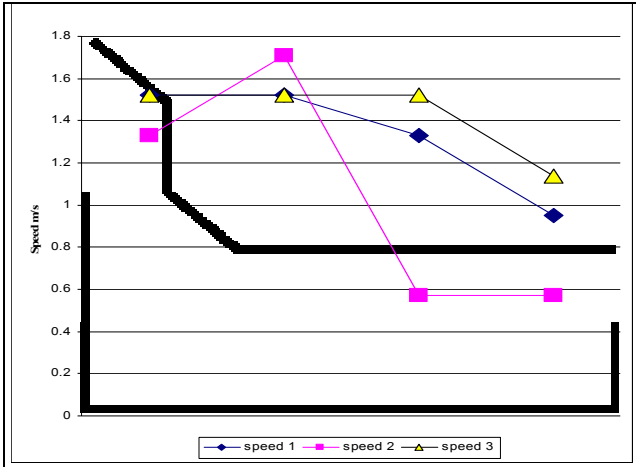

Fig. 13: Speed Vs Location.

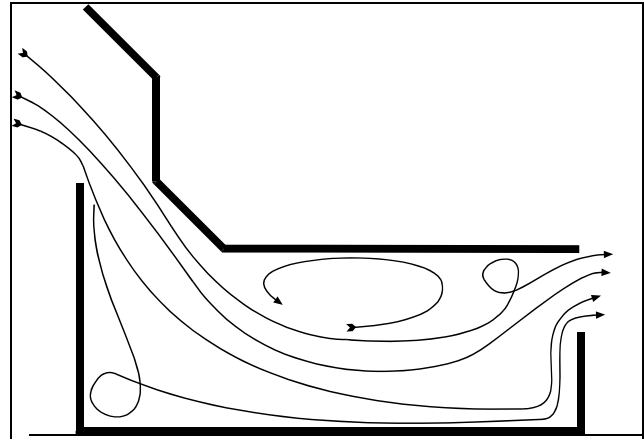

Fig. 15: Side View.

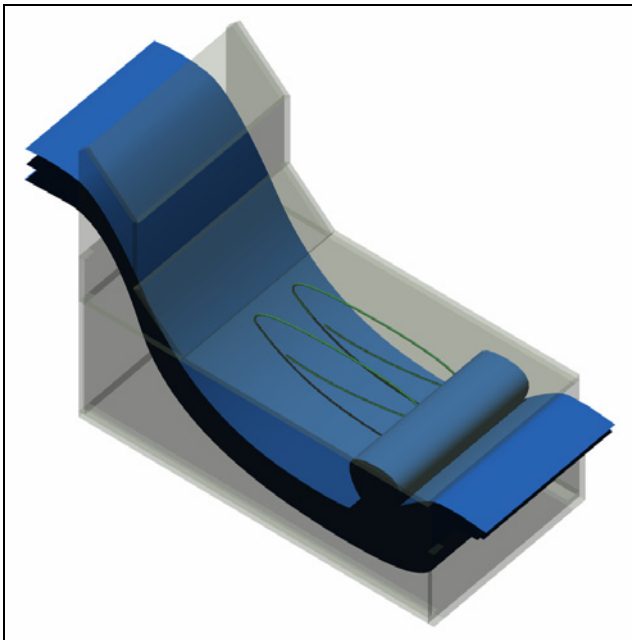

Fig. 14: 3D Drawing.

## 7. ACKNOWLEDGEMENTS

The authors wish to thank Murray Milne from UCLA, D. E. Ordway from Sage Action Inc. and Ahmad Alawar for their support, assistance and kindness.

## 8. REFERENCES

The Helium Bubble Generator can be purchased from Sage Action, Inc.  
P.O.Box 416,  
ITHACA, NEW YORK 14851  
[www.sageaction.com](http://www.sageaction.com)